



**BlowerDoor GmbH**  
MessSysteme für Luftdichtheit



## Minneapolis Micro Leakage Meter

Airtightness testing of ventilation duct systems  
according to EN 12599





The Energy Conservatory

Minneapolis BlowerDoor  
manufactured by The Energy Conservatory, Minneapolis, MN, USA



**BlowerDoor GmbH**  
MessSysteme für Luftdichtheit

Sole Agency for Europe, Springe-Eldagsen, Germany

**Copyrighted and published by**

BlowerDoor GmbH  
MessSysteme für Luftdichtheit  
Zum Energie- und Umweltzentrum 1  
D-31832 Springe-Eldagsen

Phone +49 (0) 50 44 / 975 -40

Fax +49 (0) 50 44 / 975 -44

info@blowerdoor.com

www.blowerdoor.com

All rights reserved. This Reference Guide including all illustrations is copyright protected. Any use beyond the scope of use granted by copyright law without prior approval of the publishers is unlawful and can be prosecuted. This particularly applies to copying, translating, microfilming, as well as storing and processing in electronic systems.

# Contents

<b>1</b>	<b>Introduction .....</b>	<b>6</b>
1.1	Scope of Application of the Minneapolis Micro Leakage Meter .....	6
1.2	Using the Minneapolis Micro Leakage Meter for Testing the Airtightness of Ventilation Ductwork.....	7
<b>2</b>	<b>Installation.....</b>	<b>8</b>
2.1	System Requirements.....	8
2.2	Installing TECLOG Software .....	9
<b>3</b>	<b>Setting up the Minneapolis Micro Leakage Meter Measuring System for Testing the Airtightness of Ventilation Ductwork.....</b>	<b>10</b>
3.1	Required BlowerDoor Components.....	10
3.2	Individual Parts of the Minneapolis Micro Leakage Meter.....	11
3.3	Mounting and Installing the Minneapolis Micro Leakage Meter .....	12
3.3.1	Fitting the connecting hose to the ventilation duct.....	12
3.3.2	Fitting the connecting hose to the DuctBlaster B fan .....	13
3.3.3	Installing the Minneapolis Micro Leakage Meter.....	13
3.3.4	Disks in the Minneapolis Micro Leakage Meter and changing the disks.....	14
3.4	Installing and Connecting the Speed Controller and the Pressure Gauge.....	15
3.5	Connecting the Pressure Gauge to the Computer (laptop) .....	16
3.6	Tube Connections .....	17
3.6.1	Connecting the transparent tube to the ventilation duct.....	17
3.6.2	Connecting the tubes to the Minneapolis Micro Leakage Meter .....	17
3.6.3	Connecting the tubes to the pressure gauge .....	18

<b>4</b>	<b>Computer-controlled Measurements with TECLOG .....</b>	<b>19</b>
4.1	Program Structure of the TECLOG Software.....	19
4.1.1	Overview .....	19
4.1.2	Help .....	21
4.1.3	Data export for the evaluation and drawing up a test report.....	21
4.2	Preparation and Software Settings Before Starting the Measurement .....	22
4.2.1	Default settings in TECLOG for MLM Measurement .....	22
4.2.2	Display of the registered measuring devices.....	24
4.2.3	Overview of channel settings .....	26
4.2.4	Setting up the pressure differential channels of the DG-1000 or DG-700 .....	27
4.3	Starting, Saving, and Ending Measurements .....	28
4.4	Data Recording Mode: Overview of the Working Window .....	29
4.4.1	Overview: Controlling the measuring device via the control panel.....	30
4.4.2	Overview: Live diagram with measuring curve .....	33
4.4.3	Overview: File View .....	35
4.5	Conducting Measurements According to European Standard EN 12599.....	37
4.5.1	Enter disk.....	38
4.5.2	Starting the target pressure adjustment.....	39
4.5.3	Starting a measuring period .....	39
4.5.4	Ending measurements.....	40
4.5.5	Exporting measuring data in order to create the test report.....	42
<b>5</b>	<b>Creating a Test Report According to European Standard EN 12599.....</b>	<b>43</b>
5.1	Opening the Test Report Template .....	43
5.2	Loading the Export File into the Test Report Template.....	44
5.3	Editing the Test Report .....	45

**Appendix A: Technical Data of the Minneapolis Micro Leakage Meter in Combination with a DuctBlaster B Fan as Pressure Generator ..... 46**

**Appendix B: Calibration ..... 47**

**Appendix C: Other Set-ups for Measurements with Micro Leakage Meter ..... 49**

**Our Service Offer ..... 52**

**Guarantee ..... 54**

# 1 Introduction

The Minneapolis Micro Leakage Meter Measuring System has been designed to inspect the airtightness of the ductwork during the quality control of ventilation systems.

It allows you to conduct measurements with high pressure differentials (up to 250 Pascal) and small air flows of 0.17 to 78.5 m<sup>3</sup>/h.

You can also use the Minneapolis Micro Leakage Meter to check and measure the leakage rate of low-volume, very airtight rooms.

Measurements with the Minneapolis Micro Leakage Meter (MLM) require a BlowerDoor measuring fan DuctBlaster B, including a speed controller, a DG-1000 or a DG-700 pressure gauge, and a laptop (computer).

## 1.1 Scope of Application of the Minneapolis Micro Leakage Meter

- Determination of airtightness or air permeability of ventilation ductwork according to the requirements of European Industrial Standard EN 12599, and in order to establish the airtightness class of ductwork.
- Leakage detection during the construction phase for quality assurance purposes when installing ventilation ductwork.
- Functional test and detection of leakages in existing ventilation ductwork.
- Special measurements with small air flows, e.g., of clean rooms (operating theaters, labs), for fire protection (determining the hold time for extinguishing gas), etc.
- The Minneapolis Micro Leakage Meter Measuring System is also suitable for measuring individual building elements installed in different building structures (e.g., windows, doors, or electrical installation boxes). To this end, you'll need to manually construct a test device around the building element.



**Note:**

For the measurement of ventilation ductwork, prevailing regulations must be complied with. The use of the TECLOG MLM software (version [TECLOG4](#)) and the test report does not provide exemption from knowledge of national regulations.

## 1.2 Using the Minneapolis Micro Leakage Meter for Testing the Airtightness of Ventilation Ductwork

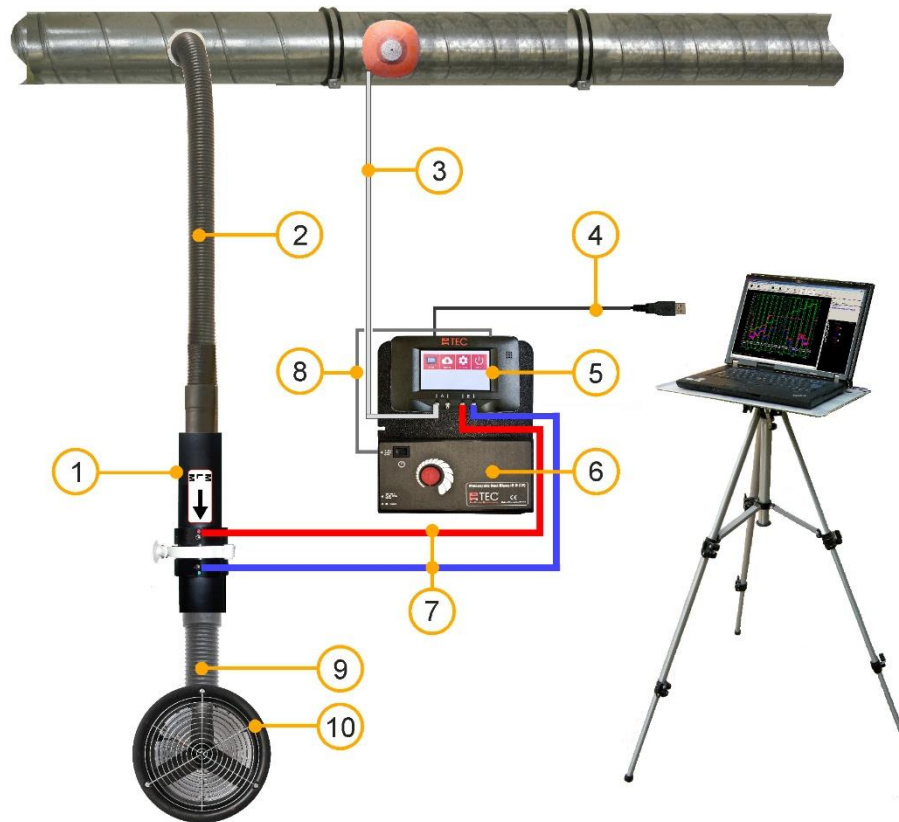

- |  |  |
|--|--|
| 1 Minneapolis Micro Leakage Meter (MLM)  | 7 Set of silicone tubes, red and blue (3 m each) [connection MLM – DG-1000; determining the MLM pressure differential] |
| 2 Connecting hose to the ductwork  | 8 Fan control cable [connection DG-1000 – fan speed controller]  |
| 3 Silicone tube, transparent (10 m) with capillary tube [for determining the pressure in the ventilation duct] | 9 Connecting hose to the DuctBlaster fan   |
| 4 USB cable [connection DG-1000 – laptop]  | 10 BlowerDoor fan DuctBlaster B with hose connection plate   |
| 5 Digital pressure gauge DG-1000   |  |
| 6 Fan speed controller for DuctBlaster B   |  |

*Fig. 1.1: Exemplary set-up of the Minneapolis Micro Leakage Meter Measuring System when testing the airtightness of ventilation ductwork; here with the pressure gauge DG-1000. WiFi connection between pressure gauge and laptop is possible.*

## 2 Installation

### 2.1 System Requirements

#### Computer

The computer/notebook/laptop must meet the following requirements:

- Pentium 233-MHZ processor
- 512 MB RAM
- USB port, Ethernet port or WiFi (if measuring with DG-1000) as well as an Internet connection for USB port driver installation of DG-1000
- USB or RS232 port or WLAN port (if measuring with DG-700)
- The connected computer must comply with IEC 60950-1 or equivalent standards on data port electrical safety isolation.

#### Operating system

TECLOG MLM software (version [TECLOG4](#)) runs on the full versions of the following operating systems:

- Windows 7
- Windows 8
- Windows 10

#### Other programs

To generate a test report:

- Excel 2007 or newer



## 2.2 Installing TECLOG Software

Before installing *TECLOG4* software, close all programs including the virus scanner on your computer. Then start installing the software by double-clicking on the installer file *TECLOG4\_VERSION\_SETUP.EXE* and following the installation instructions.

Unless you choose another path, *TECLOG4* is saved in the following folder:

*C:/PROGRAM FILES/ENERGY CONSERVATORY/TECLOG4.*

 You can open *TECLOG4* from the icon on your desktop, via the Windows Start Menu → *START* → *ALL PROGRAMS* → *ENERGY CONSERVATORY* → *TECLOG4* or using the configuration file *TECLOG4* “*CONFIG\_MLM\_DUCT-TEST.TECLOGCONFIG*” (see Section 4.2.1).

Fig. 2.1

We recommend establishing the default settings immediately following the installation. You will only have to select your default settings once (see Section 4.2.1). Also register the measuring devices in *TECLOG4* and assign the channels (see Section 4.2.3).

**Note:**

Turn off the Bluetooth function of your laptop during the measurements with *TECLOG4*; otherwise, the communication between *TECLOG4* and the measuring device may be interrupted.

### 3 Setting up the Minneapolis Micro Leakage Meter Measuring System for Testing the Airtightness of Ventilation Ductwork

#### 3.1 Required BlowerDoor Components

For the use of the Minneapolis Micro Leakage Meter (MLM) you will need the following BlowerDoor components:



Fig. 3.1: DuctBlaster B fan



Fig. 3.2: Speed controller



Fig. 3.3: DG-700 pressure gauge resp. DG-1000 pressure gauge

As illustrated in the set-up in Fig. 1.1, the Minneapolis MLM is connected to a supply or exhaust air valve in the ventilation ductwork.

A power supply (220-240 V) is required.

### 3.2 Individual Parts of the Minneapolis Micro Leakage Meter



**Minneapolis Micro Leakage Meter (MLM) including disks 1 to 4 in padded bag.**

The Minneapolis Micro Leakage Meter and its disks are marked with a serial number MLM-####. The calibration of the disks is only valid when conducted together with the respective Micro Leakage Meter.

Fig. 3.4: Minneapolis Micro Leakage Meter



Fig. 3.5



Fig. 3.6

**Connecting hose (long, 3 m), four fittings including hose clamps, plus five foam rings for connecting the MLM to the ventilation duct.**



**Connection plate with connecting hose (short, 1 m)**  
for connecting the MLM to the DuctBlaster B measuring fan.

(For further applications, the shipment includes a second connection plate.)

Fig. 3.7

### 3.3 Mounting and Installing the Minneapolis Micro Leakage Meter

#### 3.3.1 Fitting the connecting hose to the ventilation duct



The black connecting hose (long, 3 m; Fig. 3.5) with the adapter pieces (Fig. 3.6) is fitted to the ventilation duct to be tested. To make the installation easier, we recommend demounting the supply or exhaust air valve and using the fittings and foam rings to attach the connecting hose on the free duct end.

Abb. 3.8

### 3.3.2 Fitting the connecting hose to the DuctBlaster B fan



Fig. 3.9

Use the flexible connecting trim to fix the connection plate to the DuctBlaster B measuring fan. The profile encloses the edge of the fan as well as the edge of the connection plate.

The short connecting hose is preinstalled on the connection plate and fixed with a hose clamp.



**Take note of the direction of the air flow:**

When conducting depressurization measurements, the connection plate is fitted on the motor side of the fan (with pressure sensor). Air is sucked out of the ventilation duct. For pressurization tests, the connection plate is installed on the fan side with the exhaust guard. Air is transported into the ventilation duct.

### 3.3.3 Installing the Minneapolis Micro Leakage Meter



Fig. 3.10

The Minneapolis Micro Leakage Meter is installed between the two connecting hoses and fixed with hose clamps.



**Take note of the direction of the air flow:**

When conducting depressurization tests, the arrow on the MLM points to the fan. When conducting pressurization tests, the arrow points to the ventilation duct.

### 3.3.4 Disks in the Minneapolis Micro Leakage Meter and changing the disks

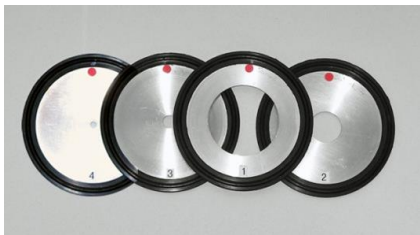

Fig. 3.11

Each disk has a defined measuring range (see Appendix B): Disks 3 and 4 have only been calibrated for a testing pressure of 80 Pa. For measurements with pressure differentials of up to 250 Pa, select disks 1 and 2.



**Note:**

For any measurement, a disk must be installed!

If the desired target pressure cannot be achieved, the **disk aperture is too small**. Use a disk with a larger aperture.

If during a measurement with *TECLOG4* the measurement value display under *FLOW* (air flow) shows the warning *LOW* (Fig. 3.12), the pressure differential at the disk is too low to perform an analysis.

The **disk aperture is too large**. A disk with a smaller aperture must be installed.



Fig. 3.12: Low – Pressure differential at the disk is too low

#### Changing the disks



Fig. 3.13

To change the disks open the white screw terminal and the two halves of the MLM. Insert the right disk observing the flow direction:

**The red and blue color markings on the disk must correspond to the markings on the MLM.**

Close the MLM and affix it by slightly tightening the screw terminal.

### 3.4 Installing and Connecting the Speed Controller and the Pressure Gauge



Fig. 3.14

The speed controller of the measuring fan is installed on the laptop rack, for example. It is then connected to the DuctBlaster B measuring fan and the power supply.



Make sure you have switched off the speed controller before connecting it to the power supply. The toggle switch of the controller must be at zero and the control knob turned to the minimum.

The DG-1000 is mounted on the gauge board using the four magnets on its backside; DG-700 is installed with Velcro tabs.



Fig. 3.15

The DG-1000 or DG-700 is then connected to the measuring fan controller using a jack cable.



Fig. 3.16: Jack cable

### 3.5 Connecting the Pressure Gauge to the Computer (laptop)

For measurements with the TECLOG MLM Software (version [TECLOG4](#)), the DG-1000 or DG-700 must be connected to a laptop and to the speed controller. For detailed information, see also the BlowerDoor MiniFan reference guide.



Fig. 3.17

#### DG-1000 communication ports

- Build-in WiFi module
- Micro USB port (left mark) for USB cable connection to the computer/laptop
- Ethernet port (center mark) for connecting a CAT cable (CAT5 twisted) to a router or switch running DHCP
- Jack plug (right mark) for connecting the jack cable to the speed controller.



Fig. 3.18

#### DG-700 communication ports

- Mini-USB port (left mark) for USB cable connection to the computer/laptop.
- 9-pole RS232 interface (center mark) for
  - connecting a TEC WiFi Link for wireless connection to laptop or a
  - serial data cable for connection to the laptop.
- Jack plug (right mark) for connecting the jack cable to speed controller.

If the [TECLOG4](#) software does not recognize the pressure gauge, check the DG-1000 connection settings or DG-700 connection settings (see Section 4.2.2).

**Note :**

Before storing the pressure gauge in its pocket, remove all connected cables.



## 3.6 Tube Connections

### 3.6.1 Connecting the transparent tube to the ventilation duct



Fig. 3.19

To record the internal pressure of the duct, the transparent tube is connected to the ventilation duct by means of a capillary tube. To do so, the ventilation duct is opened at one of the ventilation valves and the capillary tube is placed in the duct. With a rubber bladder, the duct is then closed again. The transparent tube leading to the DG-700/DG-1000 is connected at the outside end of the capillary tube.

### 3.6.2 Connecting the tubes to the Minneapolis Micro Leakage Meter



Fig. 3.20

To determine the air flow, the red tube is connected to the slot on the Minneapolis Micro Leakage Meter marked in red. The blue tube is connected to the blue slot on the MLM.

### 3.6.3 Connecting the tubes to the pressure gauge

Use the on/off button to turn the DG-1000 pressure gauge or DG-700 on and off.

**Do not change the position of the DG-1000/DG-700 during the measurement.**

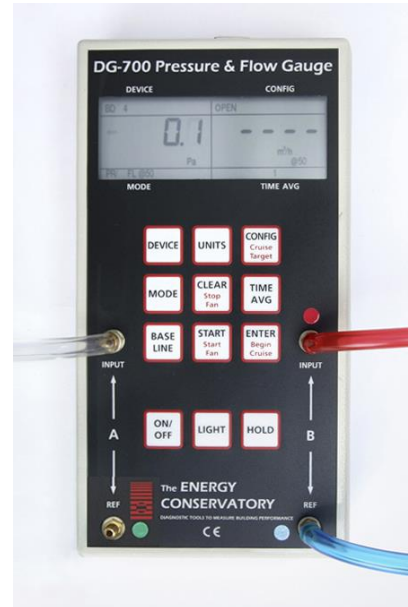

Fig. 3.21: Tube connections at DG-1000 and DG-700

#### Channel A: Recording the pressure differential in the ventilation ductwork

INPUT: Transparent tube  
(for recording the internal pressure of the ventilation duct)

REF: Open  
(for recording the outside pressure)

#### Channel B: Recording the MLM pressure differential

INPUT: red tube

REF: blue tube

## 4 Computer-controlled Measurements with TECLOG

TECLOG MLM (version *TECLOG4*) allows you to control the DuctBlaster B measuring fan, to automatically adjust the target pressure in the duct system to be measured, and to record the complete measurement series.

The subsequent sections will only elaborate on the software components that are useful for, and relevant to, testing ventilation ductwork. Further functions of *TECLOG4* necessary for measuring the airtightness of buildings and for conducting measurements with several measuring devices are explained in the BlowerDoor MultipleFan reference guide. (Please consult our website at [www.blowerdoor.com](http://www.blowerdoor.com) and click the “Downloads and Information” button.)



### **Note:**

When measuring ventilation ductwork, prevailing regulations must be complied with. The use of the TECLOG MLM software (version *TECLOG4*) and the test report does not provide exemption from knowledge of national regulations.

### 4.1 Program Structure of the TECLOG Software

#### 4.1.1 Overview

*TECLOG4* has three different operating modes:

- Inactive mode
- Data recording mode with a live diagram of the measuring curves and a digital display of the measurement values
- File view mode



Fig. 4.1: Inactive mode

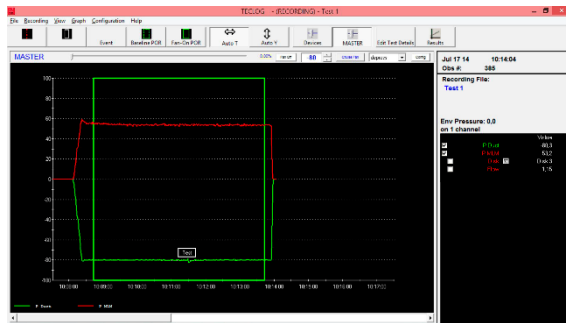

Fig. 4.2: Data recording mode

### Inactive mode (set-up mode)

Before starting the measurement, the pressure gauge must be registered and the differential pressure channels assigned.

Menu: → [CONFIGURATION](#) → [SETTINGS](#)

For further information, consult Section 4.2.

### Data recording mode (measuring mode)

In the data recording mode, all values measured by the pressure gauge are digitally displayed in the form of measuring curves. At the same time, the measured data is recorded in a file and saved.

Above the diagram is the control panel for the measuring fan. We recommend only using the central controller [MASTER](#) at all times.

#### Starting the data recording mode:

Menu: → [RECORDING](#) → [START RECORDING](#)

#### Ending the data recording mode:

Menu: → [RECORDING](#) → [STOP RECORDING](#)

For further information, consult Section 4.4.

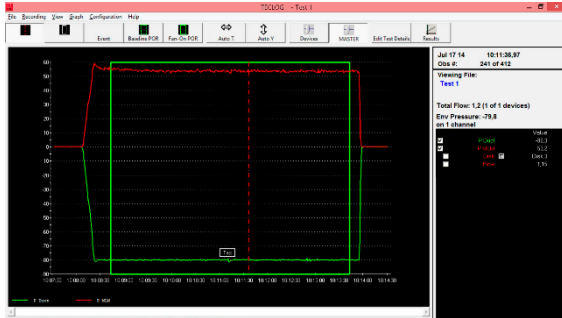

Fig. 4.3: File view mode

### File view mode (display mode)

In the file view mode, you can later view and edit the recorded measurements.

Once you have marked a measuring period, the air flow at the testing pressure  $p_{test}$  is displayed on the right as a mean value.

Loading a saved file:

Menu: → **FILE** → **LOAD DATA FILE**

For further information, consult Section 4.5.4.

### 4.1.2 Help

The help file is available in English by selecting Menu → **HELP** → **CONTENTS**.

To shortcut to the help file, hit your computer's **F1** key.

### 4.1.3 Data export for the evaluation and drawing up a test report

To draw up a test report, the measuring data is exported from the **TECLOG4** software as a text file (Section 4.5.5) and fed into the test report template included in the shipment (Section 5). All data necessary for drawing up a test report must be completed; you can then print the measurement protocol.

## 4.2 Preparation and Software Settings Before Starting the Measurement

Before starting the measurement, complete the following in *TECLOG4*:

1. Configure the default settings for conducting measurements of ventilation ductwork.
2. Register your DG-1000 or DG-700.

### 4.2.1 Default settings in TECLOG for MLM Measurement

The software includes the file „*CONFIG\_MLM\_DUCT-TEST.TECLOGCONFIG*“, which contains the required default settings for testing ventilation ductwork according to European Standard EN 12599.

Start *TECLOG4* by double clicking on „*CONFIG\_MLM\_DUCT-TEST.TECLOGCONFIG*“.

Or, when the *TECLOG4* software is already open, do the following:

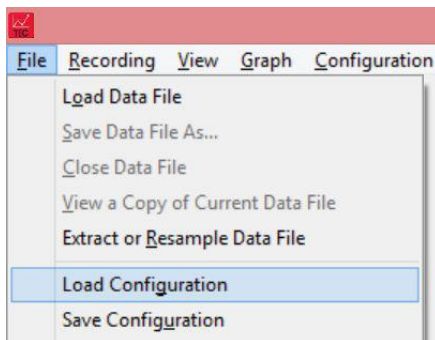

Load the default settings by selecting:

Menu: → *FILE* → *LOAD CONFIGURATION*

Select the file „*CONFIG\_MLM\_DUCT-TEST.TECLOGCONFIG*“

Fig. 4.4: Load configuration

### Overview of the parameters set

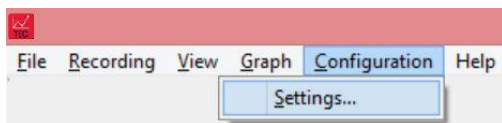

Open the *CONFIGURATION SETTINGS* window (default settings):

Menu: → *CONFIGURATION* → *SETTINGS*

Fig. 4.5: Open the Configuration Settings window

Configuration Settings (Saved when Storing Configuration File)

**Acquisition**

Sample Interval: 1.0 seconds

Pressure Autozero Interval: 1.00 minutes

**Graph**

Graph Memory during Recording: 18000 points

Auto Time Interval: 10.0 minutes

Auto-scroll Mode: 25% Scroll

White Background

Horizontal Grid

Vertical Grid

Event Marker Color: ■    Period Of Record Color: ■

Baseline POR Length: 10 seconds

Fan-On POR Length: 300 seconds

**Advanced**

Startup y-max value: 100.0

Startup ymin value: -100.0

Automatic File Capture     Dynamic Time Scrollbar

Daily File Save

Skip this port during device search: None

**Device Settings**

<input checked="" type="checkbox"/>	Device Type	Serial #	Device Label	link	<input type="checkbox"/>	Device Type	Serial #	Device Label	link
<input checked="" type="checkbox"/>	DG1000	00000	PDuct - MLM	<input checked="" type="checkbox"/>	<input type="checkbox"/>	select			<input checked="" type="checkbox"/>
<input type="checkbox"/>	select			<input checked="" type="checkbox"/>	<input type="checkbox"/>	select			<input checked="" type="checkbox"/>
<input type="checkbox"/>	select			<input checked="" type="checkbox"/>	<input type="checkbox"/>	select			<input checked="" type="checkbox"/>
<input type="checkbox"/>	select			<input checked="" type="checkbox"/>	<input type="checkbox"/>	select			<input checked="" type="checkbox"/>
<input type="checkbox"/>	select			<input checked="" type="checkbox"/>	<input type="checkbox"/>	select			<input checked="" type="checkbox"/>
<input type="checkbox"/>	select			<input checked="" type="checkbox"/>	<input type="checkbox"/>	select			<input checked="" type="checkbox"/>
<input type="checkbox"/>	select			<input checked="" type="checkbox"/>	<input type="checkbox"/>	select			<input checked="" type="checkbox"/>
<input type="checkbox"/>	select			<input checked="" type="checkbox"/>	<input type="checkbox"/>	select			<input checked="" type="checkbox"/>

Scan for Ports/Devices    View and Edit Channel Settings    Configure WiFi Settings

**Airtightness Test Settings**

Test Standard:  ASTM E779     EN 13829     CGSB     ISO 9972

USACE Compliant     Weighted Regression

Temperature Units:  Degrees F     Degrees C

Flow Units:  CFM     L/s     m<sup>3</sup>/h

Length Units:  Feet, inches     Meters, cm

SAVE AS DEFAULT CONFIGURATION

Restore Factory Settings (U.S.)    Restore Factory Settings (Europe)    OK    Cancel

Changes made to this screen will be applied to the already running program if you click OK. All of the configurable settings are on this screen. If you would like these settings to also be automatically applied next time you run Teclog click on SAVE AS DEFAULT CONFIGURATION before clicking OK.

Fig. 4.6: Configuration Settings window

Under **FAN-ON POR** (POR = period of record) in the group field **GRAPH**, 300 seconds has been preset as the measuring time for one measuring period. If required, this can be adjusted.

Device Settings

<input checked="" type="checkbox"/>	Device Type	Serial #
<input checked="" type="checkbox"/>	DG1000	00000

Fig. 4.7: Required Input

In the group field **DEVICE SETTINGS**, activate the connected digital pressure gauge by clicking the control box on the left of the column **DEVICE TYPE** so that a checkmark appears.

## 4.2.2 Display of the registered measuring devices

By clicking the [SCAN FOR PORTS/DEVICES](#) button, all computer ports can be scanned for connected measuring devices, and devices currently connected can be displayed with their serial number.

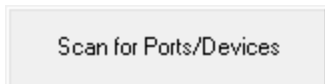

Click on the button [SCAN FOR PORTS / DEVICES](#).

All computer ports are scanned for connected measuring devices.

Fig. 4.8

If the computer has an internal modem, this is displayed with the notification [SKIP THIS PORT?](#). Confirm this notification by clicking [YES](#). The modem will no longer be considered.

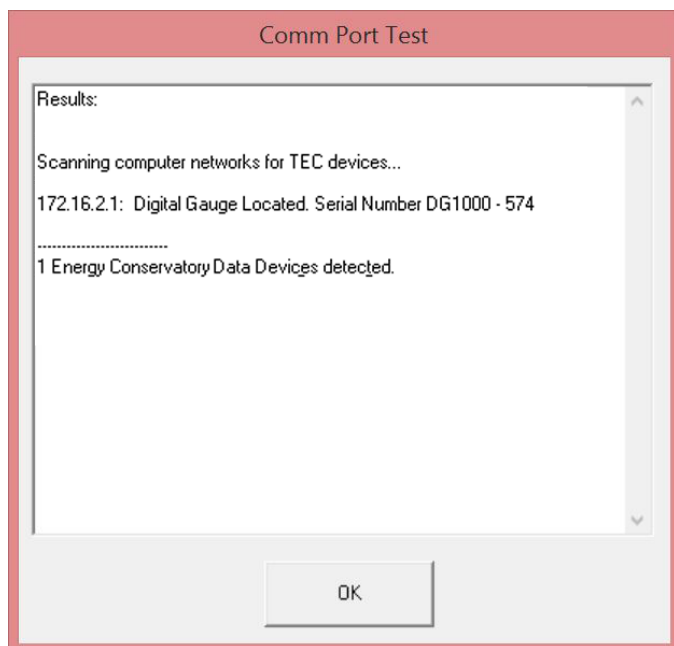

Fig. 4.9: Comm Port Test window

Following the scan, all properly connected measuring devices are displayed in the [COMM PORT TEST](#) window.

They are listed with the assigned COM port number (if using a DG-700 via USB) or the network number (if a DG-1000 is connected or a DG-700 via WiFi), the measuring device type and the serial number.

Exit the window by clicking on [OK](#).



Should your measuring device not appear in the list, check the following:

- Is your measuring device switched on?
- Is your measuring device connected to the laptop?
- Has the COM port been created in the Windows Device Manager for DG-700 pressure gauge?
- Have the drivers been installed correctly?
- If the Bluetooth function of your laptop is still active, turn it off, because it may disturb communication between the measuring device and *TECLOG4*.

Then repeat the port scan by clicking on the *SCAN FOR PORTS / DEVICES* button.

For further information on *TECLOG4*, please consult the BlowerDoor MultipleFan reference guide (see our website at [www.blowerdoor.com](http://www.blowerdoor.com) in the Downloads section).

### Save as default configuration

If you would like to always use *TECLOG4* with the same configuration, save the latter as the default.

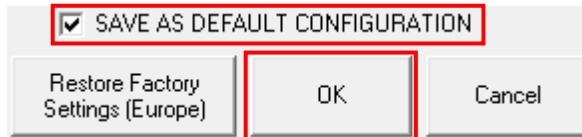

Fig. 4.10: Save as default configuration

- To save a configuration as the default, check the option *SAVE AS DEFAULT CONFIGURATION*.
- Confirm by clicking *OK*.

### 4.2.3 Overview of channel settings

Adjust the settings for the differential pressure channels of the DG-1000 or DG-700 pressure gauge in the *CHANNEL SETTINGS* window.

View and Edit Channel Settings

The *CHANNEL SETTINGS* window is opened by clicking on the button *VIEW AND EDIT CHANNEL SETTINGS* in the *CONFIGURATION SETTINGS* window.

Fig. 4.11: Opening the Channel Settings window

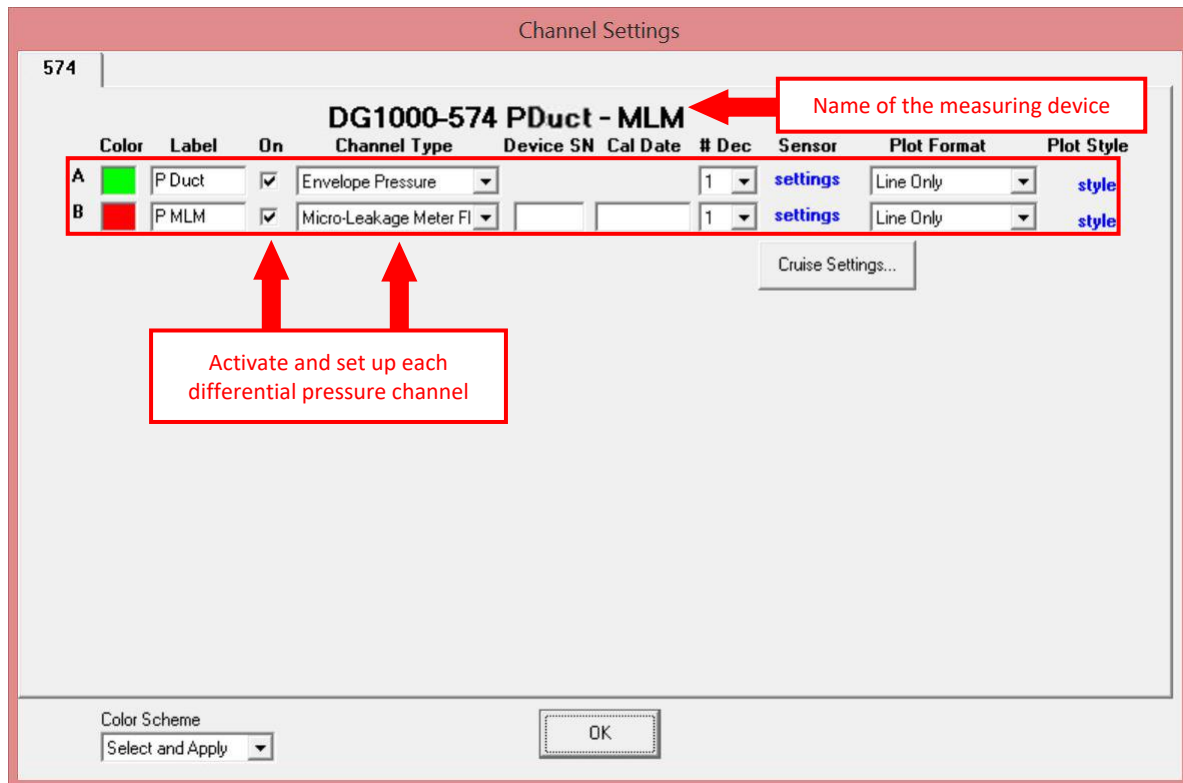

Fig. 4.12: Channel Settings window

In the configuration file „*CONFIG\_MLM\_DUCT-TEST.TECLOGCONFIG*“, the settings for the two pressure differential channels have already been adjusted for the measurement with the Micro Leakage Meter.

#### 4.2.4 Setting up the pressure differential channels of the DG-1000 or DG-700

For the DG-1000 or DG-700, you must assign each differential pressure channel (channel pressure differential or MLM pressure differential).

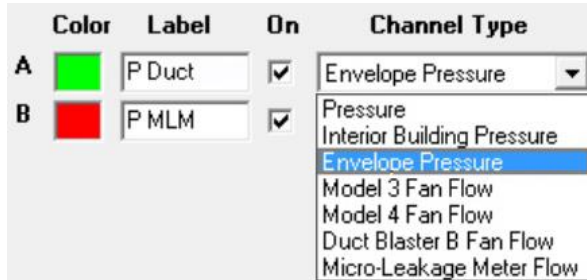

Fig. 4.13: Selecting the function for Channel A

Channel A records the pressure in the ventilation ductwork and should be set to *ENVELOPE PRESSURE*.

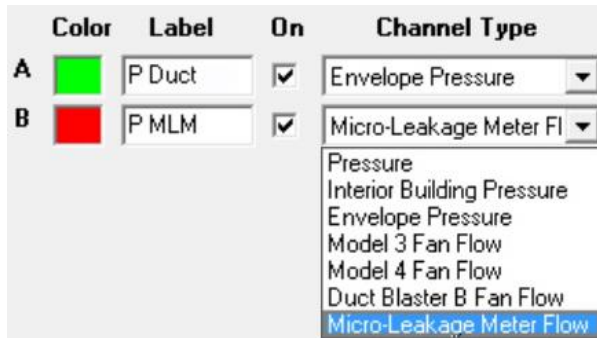

Fig. 4.14: Selecting the function for Channel B

Channel B records the pressure in the MLM and, for a correct analysis, should be set to *MICRO-LEAKAGE METER FLOW*.

In the configuration file „*CONFIG\_MLM\_DUCT-TEST.TECLOGCONFIG*“, the settings for the two pressure differential channels have already been adjusted for measurement with the Micro Leakage Meter.

### 4.3 Starting, Saving, and Ending Measurements

Once the pressure differential channels have been adjusted, you can start the measurement.

#### Starting the measurement

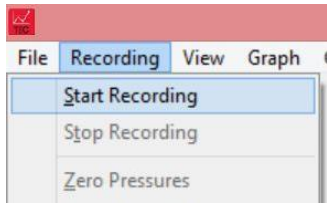

Menu: → *RECORDING* → *START RECORDING*

*TECLOG4* will first check the connection to all COM ports and the connected measuring device.

Fig. 4.15: Starting the measurement

#### Note:

If the measuring device is not found, a notification window with the message *DID NOT FIND...* appears. The missing measuring device is indicated with its serial number. Confirm by clicking on *OK*. The window *CONFIGURATION SETTINGS* will open and you can check the adjustments made and the ports created.

#### Saving the measurement

Enter a file name in the *ENTER FILENAME FOR SAVING* window.

All measured values since starting the measurement are written into this file. The file will automatically be assigned the ending *TECLOGDATA*.

#### Ending the measurement

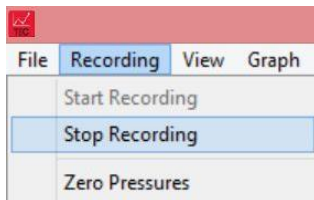

Menu: → *RECORDING* → *STOP RECORDING*

Fig. 4.16: Ending the measurement

#### 4.4 Data Recording Mode: Overview of the Working Window

Upon starting the measurement, *TECLOG4* opens in the data recording mode. All incoming measurement values are displayed digitally in real time and graphically in the form of a measuring curve. The measurement is recorded and simultaneously saved in a file.

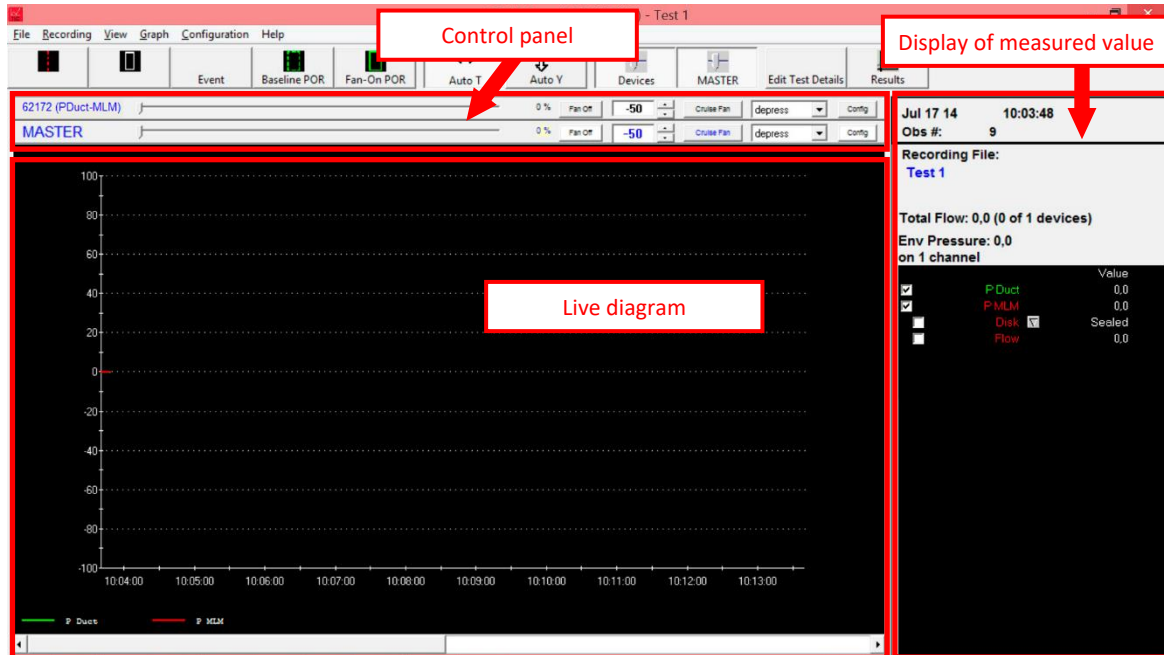

Fig. 4.17: Data recording mode of *TECLOG4*

The *TECLOG4* working window consists of three parts:

- Control panel
- Live diagram
- Digital display of the measured value.

The DuctBlaster B measuring fan is controlled via the **control panel**.

In the **live diagram**, the values measured are displayed as measuring curves. Each activated channel is represented by (at least) one measuring curve.

#### 4.4.1 Overview: Controlling the measuring device via the control panel

The DG-1000 or DG-700, connected to the speed controller of the DuctBlaster, is controlled from the control panel.

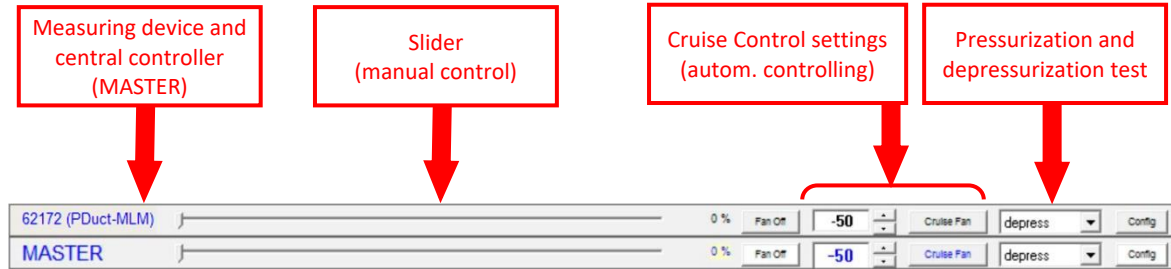

Fig. 4.18: Control panel of TECLOG4

#### Showing and hiding the control panels for the DG-1000/DG-700



By clicking the *DEVICES* button in the tool bar, the control unit for the DG-1000/DG-700 in the control panel is shown or hidden.

Fig. 4.19

#### Showing and hiding the central controller



By clicking the *MASTER* button in the tool bar, the control unit for the central controller in the control panel is shown or hidden.

Fig. 4.20



For the measurement of ventilation ductwork, we recommend only showing the *MASTER* and controlling the process from there.

**Slider (manual control of the fans)**

Fig. 4.21: Slider

Move the slider on the bar with the [LEFT MOUSE BUTTON](#). Moving it to the right will increase fan speed, moving it to the left will reduce it.

**Safety note:**

To stop the fan, click on [FAN OFF](#) or press the [ESC KEY](#) on your keyboard.

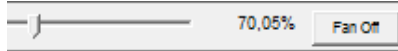
**Cruise control for automated controlling**

Fig. 4.22: Cruise

By clicking the [CRUISE FAN](#) button, [TECLOG4](#) automatically controls the constant target pressure differential (in this example: -80 Pa).

**Safety note:**

To stop the fan, click on [FAN OFF](#) or press the [ESC KEY](#) on your keyboard.

**Toggle between depressurization measurement ([DEPRESS](#)) and pressurization measurement ([PRESS](#))**

Fig. 4.23: Toggle

Exhaust air ducts are measured at negative pressure, supply air ducts at positive pressure.

Toggling from a series of depressurization measurements ([DEPRESS](#)) to a series of pressurization measurements ([PRESS](#)) or vice versa is done via the drop-down menu [PRESS / DEPRESS](#). Make sure to select an option in order for the automated control to work without problems.

**Cruise settings ([CONFIG](#))**

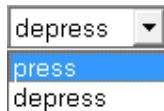
Fig. 4.24: Config

Clicking on [CONFIG](#) allows you to change the cruise settings.

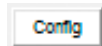
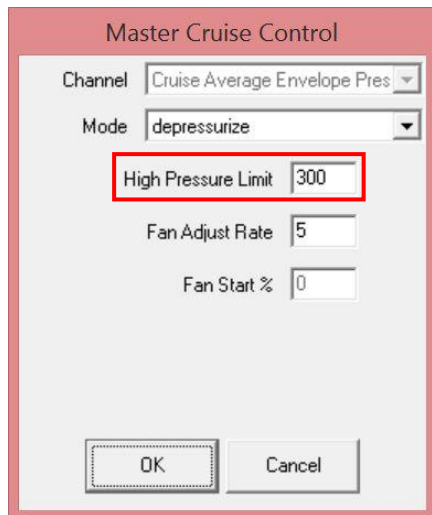

Fig. 4.25: Configuration

Clicking the *CONFIG* button opens the *MASTER CRUISE CONTROL* window. There, you can adjust the settings for automated control of the fan.

- Pressurization or depressurization method (*MODE*)
  - Negative pressure = depressurization
  - Positive pressure = pressurization
- Pressure limit for automated fan switch-off (*HIGH PRESSURE LIMIT*)

**When measuring ventilation ductwork, the standard setting of 100 Pa is usually not enough and needs to be increased accordingly.**

- Speed of the fan control is set (*FAN ADJUST RATE*).



#### 4.4.2 Overview: Live diagram with measuring curve

The measured values are shown in two ways: in the live diagram with a measuring curve (at least one) for each channel, and in the digital view of measurement values. All activated channels are displayed graphically. (Fig. 4.26).

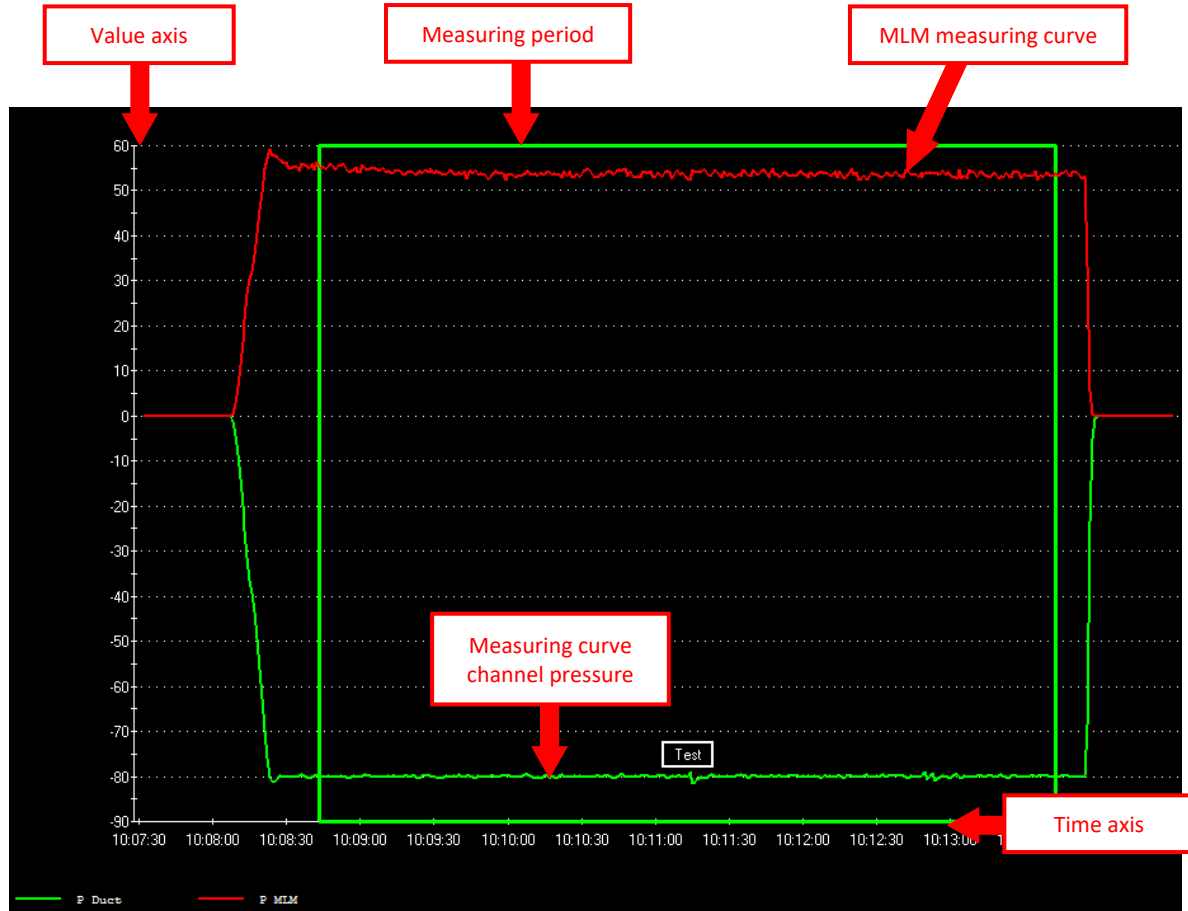

Fig. 4.26: Live diagram in the TECLOG4 working window

## Presentation of the diagram



The buttons *AUTO T* and *AUTO Y* in the tool bar allow you to toggle the automatic adjustment of the axis distribution.



Fig. 4.27

By holding down the shift key while pulling out a rectangle with the left mouse button, you can show and magnify details of the diagram.

For further options for adjusting the graphic presentation, consult the BlowerDoor MultipleFan reference guide (also see our website at [www.blowerdoor.de](http://www.blowerdoor.de) under the “Downloads and Information” button.)

## Measuring curves

Each channel of the DG-1000/DG-700 that has previously been set up in the *CHANNEL SETTINGS* (Section 4.2.3) is assigned at least one measuring curve in the live diagram. The measured values of Channel A, which is set to record the pressure differential of the ventilation duct (*ENVELOPE PRESSURE*), are displayed in a measuring curve. Channel B, which is connected to the MLM (*MICRO LEAKAGE METER*), can be displayed by up to three curves: MLM pressure differential, air flow, and the inserted disk.

## Setting up a measuring period

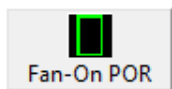

Fig. 4.28

In the live diagram, measuring ranges can be set up as measuring periods for a freely selected time frame. These marked measuring periods are used to determine the results when drawing up the report.

In the configuration file, the measuring period has been preset to 300 seconds (5 minutes).

### 4.4.3 Overview: File View

To the right of the live diagram, you can display the current measured values, the measuring values of a selected point in time, or the average values of a measuring period.

Jul 17 14 10:11:01,97  
Obs #: 207 of 412  
Viewing File:  
Test 1  
Total Flow: 1,2 (1 of 1 devices)  
Env Pressure: -79,7  
on 1 channel

	Value
<input checked="" type="checkbox"/> P Duct	-79,7
<input checked="" type="checkbox"/> P MLM	53,9
<input type="checkbox"/> Disk <input type="text" value="v"/>	Disk 3
<input type="checkbox"/> Flow	1,16

Current time and number of measuring points

File name

Air flow and pressure differential in the duct

Display of testing pressure

MLM display: Pressure, disk, air flow

Fig. 4.29: View of measured values in TECLOG4

In the *READOUTS* window, all data for monitoring the measurement is displayed:

- The current time
- Number of measuring points (*OBS #*)
- File name (*RECORDING FILE*)
- Total air flow (*TOTAL FLOW*)
- Testing pressure (*ENV PRESSURE*)
- Settings and measured values for the activated pressure channel

## Description of the File View

### Colors in the File View

Depending on what has been marked, the color in the header of the file view will change.

Dez 13 10	14:39:30
Obs #:	664

Fig. 4.30: Current measuring values

Grey: Display of the currently measured values

Selected:	1,25 minutes
Obs #:	425 - 497

Fig. 4.31: Marked measuring period

Green: When a measuring period is marked or a new period is created, the display will be green.

Dez 13 10	14:36:07,73
Obs #:	469

Fig. 4.32: Marked measuring time

Red: When a measuring time is marked in the live diagram, this display will be red.

### Display of the MLM configuration *DISK*, the pressure differentials, and the air flow

		Value
<input checked="" type="checkbox"/>	P Duct	-79,7
<input checked="" type="checkbox"/>	P MLM	53,9
<input type="checkbox"/>	Disk <input type="text" value="v"/>	Disk 3
<input type="checkbox"/>	Flow	1,16

Fig. 4.33: Digital display of the measuring values

When the control box before the channel name is activated (check mark), the measuring curve of this channel is displayed in the live diagram. When it is not activated, the curve is not displayed.

In the center column, you can view the names of the channels and the set-up options for the device/disk configuration of the MLM (*DISK*).

In the column to the right, the measurement values and the device configuration are displayed.

**MLM View is blinking**

Should the three-part display start blinking, this can be caused by one of the following:



Fig. 4.34: Unknown – Disk unknown



Fig. 4.35: Low – Disk pressure differential is too low

- The MLM configuration *DISK* is *UNKNOWN*. To change the configuration with the left mouse button, click the button to the right of *DISK*  and select the inserted disk.
- In spite of having selected the disk, there are no measuring values displayed under *FLOW* (air flow): *LOW*. Should the disk pressure differential be lower than the limit permitted, insert a smaller disk in the MLM. Select the respective disk in the *DISK* settings.

## 4.5 Conducting Measurements According to European Standard EN 12599

Starting *TECLOG4* (see Section 4.3).



Fig. 4.36: Display set-up, Master



Fig. 4.37

- Set the display to the optimum by only showing the Master.
- Select depressurization or pressurization measurement.

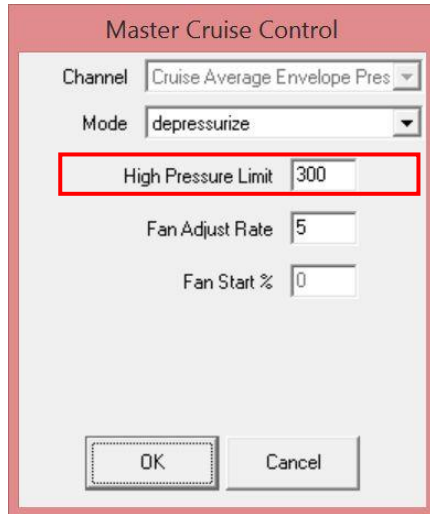

Fig. 4.38

- Use the **CONFIG** button to set the pressure limit for automatic shut-down (**HIGH PRESSURE LIMIT**) to a level sufficiently above the testing pressure.

#### 4.5.1 Enter disk

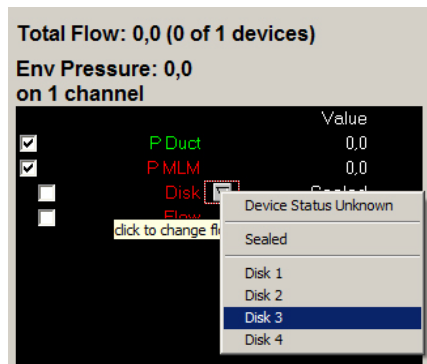

Fig. 4.39

- In order for **TECLOG4** to be able to calculate the air flow, the inserted disk must be indicated.
- Each disk has a defined measuring range with the highest possible accuracy for measuring the air flow (see Appendix B).
- Select the inserted disk in the drop-down menu.

### 4.5.2 Starting the target pressure adjustment



Fig. 4.40

- The automatic control of the measuring device first requires entering the target pressure (here -80 Pa)
- Pressing the *CRUISE FAN* button starts the cruise function. *TECLOG4* will now control the fan so that the pressure required in the ventilation ductwork (Channel A of the DG-1000/DG-700, defined as *ENVELOPE PRESSURE*) is achieved.
- If you are unable to reach the target pressure in spite of running the fan at full speed, insert a disk with a larger aperture into the MLM.

### 4.5.3 Starting a measuring period

Once you have created a stable pressure level in the ventilation duct (the duct pressure and air flow graphs in the live diagram run horizontally), the measuring period can be started.

To measure the airtightness of ventilation ducts according to European Standard EN 12599, a measuring period of 5 minutes is required. The default setting of *FAN-ON POR LENGTH* (see Section 4.2.1) of 300 seconds sets the measuring period to 5 minutes.

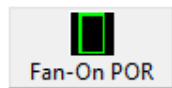

Fig. 4.41

- Start the measuring period by clicking the *FAN-ON POR* button.
- The *EDIT PERIOD OF RECORD* window will open.

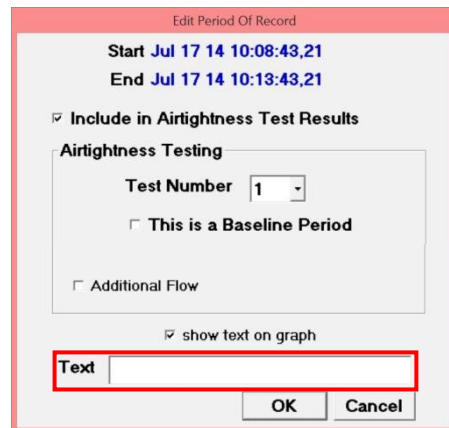

Fig. 4.42

You may enter a name (*TEXT*) for the measuring period. The other input options offered here are of no importance for airtightness tests of ventilation ductwork.

## 4.5.4 Ending measurements



Fig. 4.43

If the selected pressure has been maintained until the end of the measuring period, the DuctBlaster can be turned off via the *FAN OFF* button or the *ESC* key.

You can then stop the recording of the measuring data.

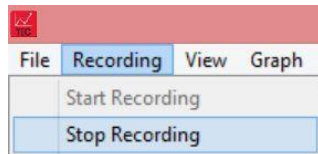

Menu: → *RECORDING* → *STOP RECORDING*

Fig. 4.44



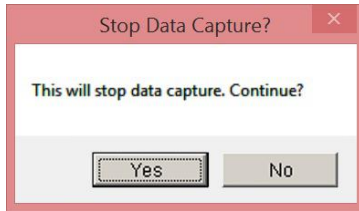

Fig. 4.45: Ending measurement?

In the *STOP DATA CAPTURE* window, you will see the notification “This will stop data capture. Continue?”

- In order to end the measurement, click on *YES*.
- In order to continue the measurement, click on *NO*.

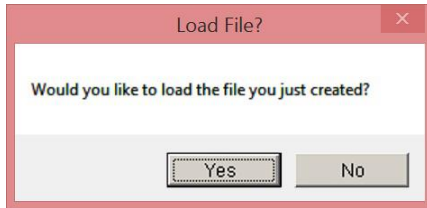

Fig. 4.46: Load file

In the *LOAD FILE?* window you are asked if you would like to open the previously created file.

- In order to display the measurement, click on *YES*.
- If you do not want to display the measurement, click on *NO*.



Fig. 4.47

### 4.5.5 Exporting measuring data in order to create the test report

The completed measurement can now be exported into the file [TEST-REPORT\\_VENTILATION\\_DUCT\\_SYSTEMS\\_VERSION.XLTM](#) in order to create the test report.

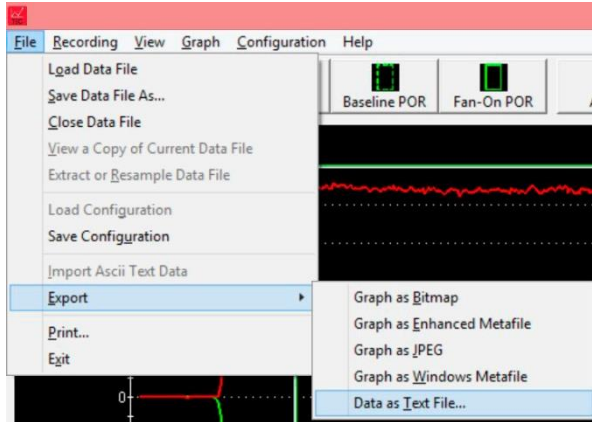

Fig. 4.48

Menu:

→ [FILE](#) → [EXPORT](#) → [DATA AS TEXT FILE](#)

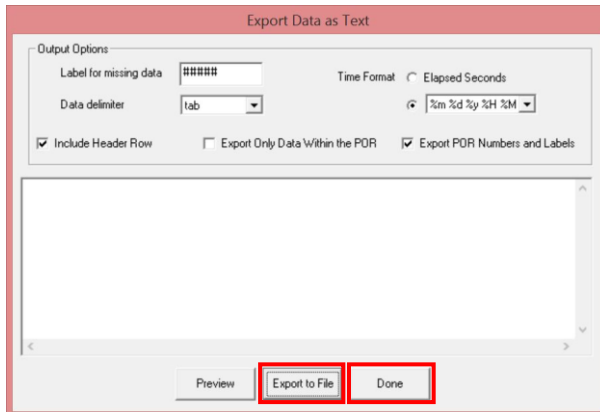

Fig. 4.49

The window that opens shows the settings for exporting the text file. To avoid any problems during the import into the test report, these settings must not be changed.

To export the data, click [EXPORT TO FILE](#). The export file can now be saved in the desired folder.

Close the window by clicking the [DONE](#) button.

## 5 Creating a Test Report According to European Standard EN 12599

*TECLOG4* software is a data logger. The program records all pressure curves for the duration of the airtightness measurement.

If you desire an analysis according to European Standard EN 12599, the test report template for airtightness tests of ventilation ductwork (file name: *TEST-REPORT\_VENTILATION\_DUCT\_SYSTEMS\_VERSION.XLTM*) is useful.

The test report template contains all necessary information for documenting airtightness tests of ventilation ductwork. Those knowledgeable in Excel can also adjust the template to their own needs.

Copy the test report template into a folder on your computer.

### 5.1 Opening the Test Report Template

Open the MLM test report template *TEST-REPORT\_VENTILATION\_DUCT\_SYSTEMS\_VERSION.XLTM* on your computer.



The file contains Macros so that the *TECLOG4* file can be loaded. In order for the read-in to work, the **Macro security** level in Excel must be set to **low** and Macros must be activated.

Save the file under a different name.

## 5.2 Loading the Export File into the Test Report Template

Use the Start window of the test report template for airtightness tests of ventilation ductwork (Fig. 5.1) to load the **TECLOG4** export file (file extension .txt) into the test report.

To load the file, click on the button **IMPORT TECLOG4 DATA (.TXT)**. A window opens, where you can select the desired export file (.txt). Once the file has been selected, all measurement data is automatically loaded into the test report.

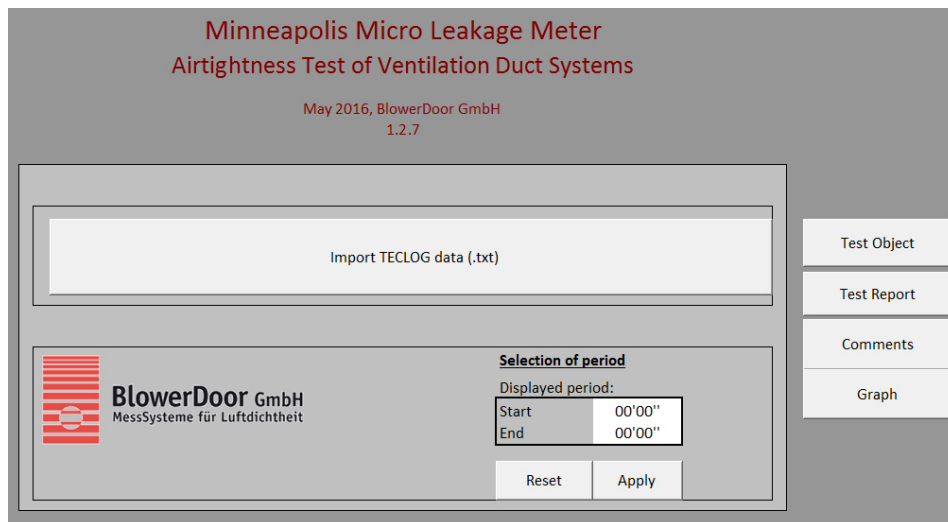

Fig. 5.1: Test report for airtightness tests of ventilation duct systems for loading export files from TECLOG4

### 5.3 Editing the Test Report

The test report for airtightness tests of ventilation ductwork contains several spreadsheets with the measuring data, the result, and its graphical display (see Fig. 5.2). Make sure that all measuring data is complete and correct. If necessary, enter the country-specific values.

Once the **TECLOGA** export file has been loaded, the data in the individual spreadsheets can be completed and printed.



Fig. 5.2: Example

## Appendix A: Technical Data of the Minneapolis Micro Leakage Meter in Combination with a DuctBlaster B Fan as Pressure Generator

Capacity	at a differential pressure of	Measuring accuracy:
2,15 m <sup>3</sup> /h – 57,4 m <sup>3</sup> /h	250 Pa	{ ± 5 % or ± 0.37 m <sup>3</sup> /h, whichever is greater (with disk 1 or 2)
2,15 m <sup>3</sup> /h – 69,7 m <sup>3</sup> /h	160 Pa	{ ± 5 % or ± 0.37 m <sup>3</sup> /h, whichever is greater (with disk 1 or 2)
0,17 m <sup>3</sup> /h – 78,5 m <sup>3</sup> /h	80 Pa	{ from 2.15 m <sup>3</sup> /h to 78.5 m <sup>3</sup> /h : ± 5 % or ± 0.37 m <sup>3</sup> /h, whichever is greater (with disk 1 or 2) from 0.65 m <sup>3</sup> /h to 3.23 m <sup>3</sup> /h : ± 5 % or ± 0.09 m <sup>3</sup> /h whichever is greater (with disk 3) ≤ 0.83 m <sup>3</sup> /h : ± 0.04 m <sup>3</sup> /h (with disk 4)
Dimensions:	L 300 mm, Ø 140 mm	
Weight:	approx. 800 g	

For the specifications of the DG-1000/DG-700 pressure gauge, the DuctBlaster B and the corresponding speed controller, please consult the BlowerDoor MiniFan reference guide.

## Appendix B: Calibration

All Micro Leakage Meters are shipped with a calibration certificate. Micro Leakage Meters basically always maintain their manufacturer's calibration as long as they are free of mechanical damage. An airtightness test of the Micro Leakage Meter is recommended every two years.

Depending on the area of application, specific national regulations apply to the calibration of the pressure gauges and the BlowerDoor measuring fan DuctBlaster B (as well as of the BlowerDoor measuring fans Model 3 and 4).

To maintain the high measuring accuracy of the gauges, we recommend ensuring regular calibration in accordance with manufacturer specifications. For the DG-1000 as well as for DG-700, an adjustment and manufacturer's calibration is recommended every two years. The accuracy of BlowerDoor measuring fans should be checked by calibration every four years. National regulations still apply.

BlowerDoor GmbH offers fan calibration as well as adjustment and factory calibration, or calibration with DAkkS certificate, of its pressure gauges (see the appendix describing our service offer).

### Calibration parameters for the disks of the Minneapolis Micro Leakage Meter

MLM configuration	Calibration parameters		
	Air-flow read	C	n
Disk 1	Flow (m <sup>3</sup> /h) =	5.669	· (MLM pressure differential in Pa) <sup>0.4880</sup>
Disk 2	Flow (m <sup>3</sup> /h) =	0.9769	· (MLM pressure differential in Pa) <sup>0.4913</sup>
Disk 3	Flow (m <sup>3</sup> /h) =	0.1832	· (MLM pressure differential in Pa) <sup>0.4811</sup>
Disk 4	Flow (m <sup>3</sup> /h) =	0.04732	· (MLM pressure differential in Pa) <sup>0.4759</sup>

**Note:**

All air flows established with the above calibration parameters are calculated under the assumption that the air flowing through the disk has a density of 1.204 kg/m. This corresponds to an air density at the ambient conditions of 20 C and 101325 Pa. If the density of the air flowing through the disk deviates from this air density, the air flow shown (read) on the measuring device does not correspond to the actual (measured) air flow.

To calculate the actual air flow with the actual air density (depending on the temperature and barometric pressure during the measurement) the manufacturer provides the following formula:

$$\text{Air flow}_{\text{measured}} (\text{m}^3/\text{h}) = \text{Air flow}_{\text{read}} (\text{m}^3/\text{h})$$

$$\sqrt{\frac{1.204 \text{ kg/m}^3}{\text{air density (kg/m}^3\text{)*}}}$$

\*) Use the density of air flowing through the disk of the MLM.

**Note:**

The test report template for airtightness tests of ventilation ductwork included in your shipment performs these calculations automatically. The air flow measured is the air flow at ambient conditions (temperature and pressure) during the measurement.

Air flow *measured* corresponds to *q<sub>vl measured</sub>* in the test report template.

**Minimum MLM pressure differential (Pa) for the disks**

Disk	minimum MLM pressure differential [Pa]	Minimum flow [m3/h]	Maximum flow [m3/h]		
			à 80 Pa	à 160 Pa	à 250 Pa
Disk 1	5 Pa	12.4	78.5	69.7	57.4
Disk 2	5 Pa	2.15	18.18	16.14	13.59
Disk 3	14 Pa	0.652	3.228	–	–
Disk 4	14 Pa	0.166	0.833	–	–

**Cleaning the Minneapolis Micro Leakage Meter**

The Minneapolis Micro Leakage Meter can be cleaned with a damp cloth.



## Appendix C: Other Set-ups for Measurements with Micro Leakage Meter

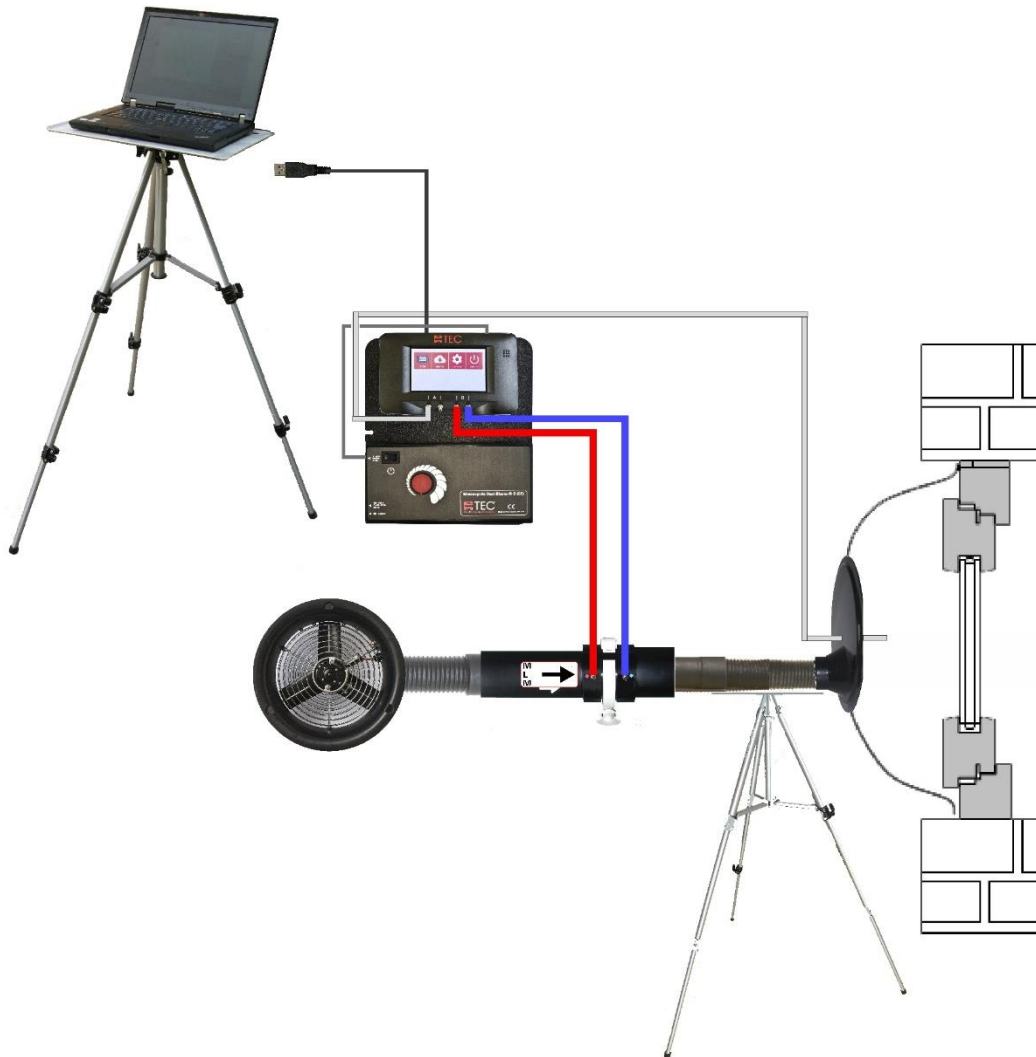

*Fig. 6.1: Exemplary set-up for testing of the air permeability through already mounted building components as windows and doors with Minneapolis Micro Leakage Meter; pressurization. Here with DG-1000 with USB cable connection.*

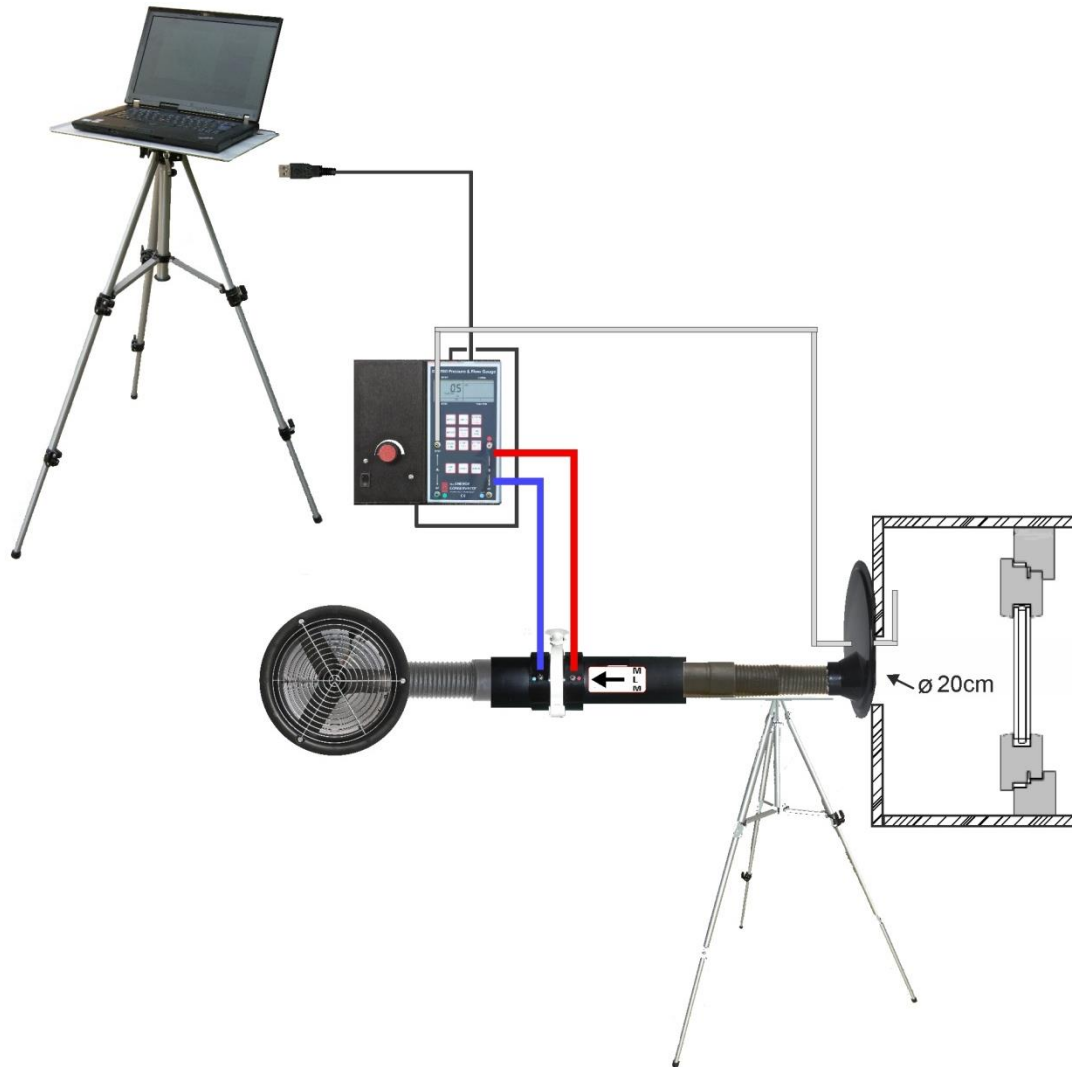

Fig. 6.2: Exemplary set-up for measurement of building components with assistance of a test case and with Minneapolis Micro Leakage Meter; depressurization. Here with DG-700 with USB cable connection.

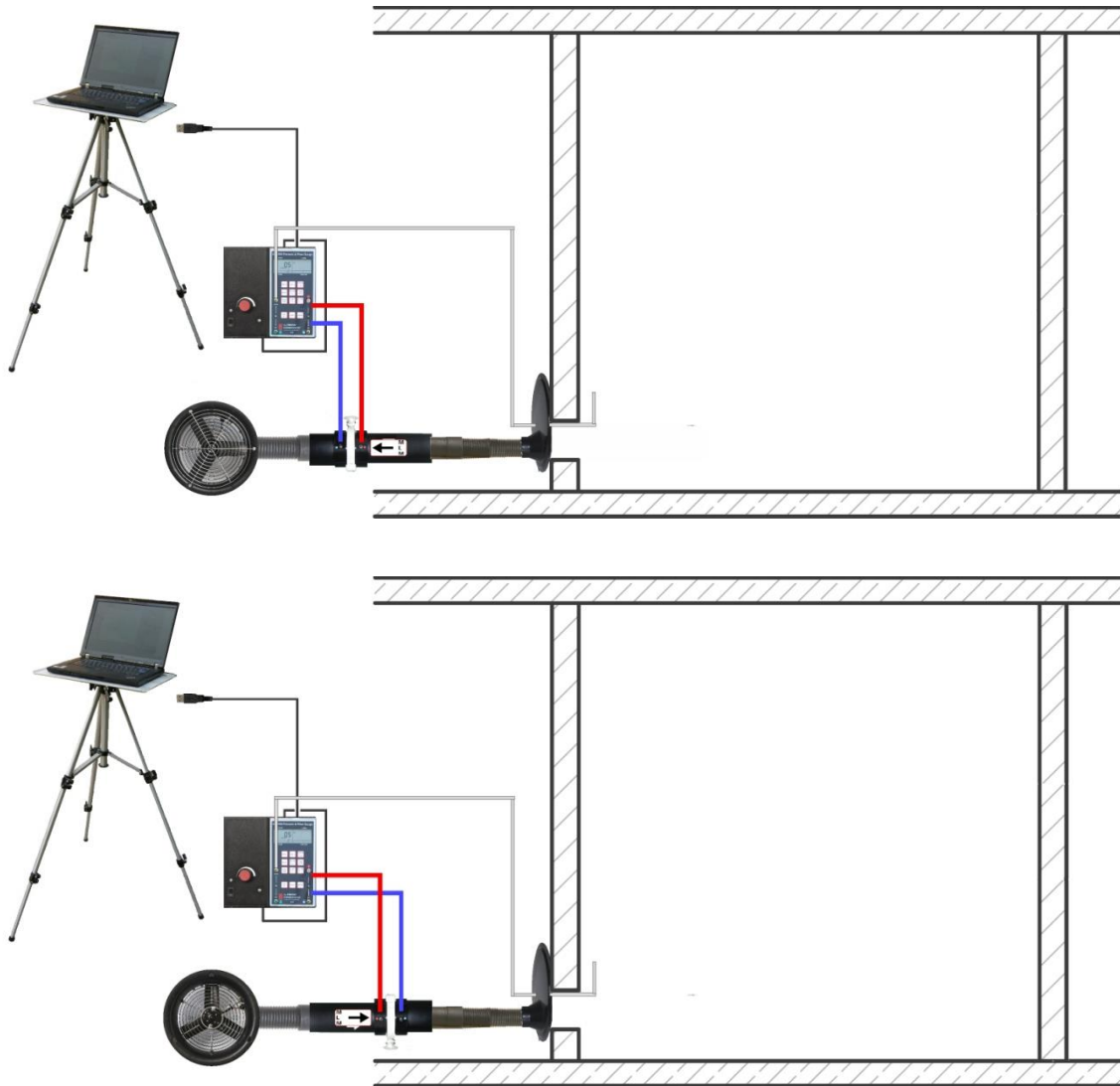

Fig. 6.4: Exemplary set-up with Minneapolis Micro Leakage Meter for measuring of very small and very tight single rooms (e.g. clean rooms, laboratories) with small airflows.  
 Top: depressurization measurement, bottom: pressurization measurement  
 The MLM is fitted to an on-site existing test aperture ( $\varnothing$  ca. 20 cm).

## **Our Service Offer**

### **Calibration of your BlowerDoor Measurement Systems**

The accuracy of the BlowerDoor measuring fan incl. flow rings at 4% (rings 1-4 resp. rings A - C) and  $\pm 5\%$  (flow rings D + E), both the accuracy of the BlowerDoor testing flow rings as well as the accuracy of the pressure gauge DG-1000 at  $\pm 0,9\%$  and DG-700 at  $\pm 1\%$  meet the legal minimum requirements.

To maintain the high measuring accuracy of the BlowerDoor Measurement System, we recommend ensuring regular calibration according to the manufacturer's specifications: For the DG-1000 and DG-700, adjustment and manufacturer's calibration is recommended at an interval of two years. The accuracy of the BlowerDoor measuring fan should be checked by calibration every four years. A previous fan check forms part of each fan calibration. The requirements of the national legislation should be considered for pressure gauge and fan. An airtightness test of the Micro Leakage Meter is recommended every two years.

In addition to the very high quality manufacturer's calibration, BlowerDoor GmbH also offers accredited calibrations with DAkkS calibration at favorable prices. Details are available on [www.blowerdoor.com](http://www.blowerdoor.com). Dates and prices for leak testing of the MLM on request.

### **Seminars and in-house training**

In addition to the extensive seminar program covering aspects of an airtight building envelope offered by the Energie- und Umweltzentrums am Deister, BlowerDoor GmbH and its contract partners also provide individual training on site or on-demand webinars. Contact us for more information!

### **Service at your construction site**

If required, we will lend our competence to support you in conducting a BlowerDoor measurement at your construction site. Contact us for an offer tailored to your needs!

### **Listing in the directory of providers of BlowerDoor measurements**

As a BlowerDoor testing team, your listing in our online database is free of charge. Contact us at [info@blowerdoor.com](mailto:info@blowerdoor.com) if you would like an address entry, including a link to your email address and website in our directory of BlowerDoor test providers.

### **CompetenceCenter**

All BlowerDoor testing teams receive access to our virtual Center of Competence at [www.blowerdoor.com](http://www.blowerdoor.com) free of charge, where we regularly provide you with news and offer interesting information for download. Contact us if you have not yet received your client number and access data from BlowerDoor GmbH.

### **Advertising material for BlowerDoor testing teams**

Upon request, we support BlowerDoor testing teams with professional printable files on BlowerDoor measurements free of charge. The material will feature your own contact data and company logo. (View a sample at [www.blowerdoor.com](http://www.blowerdoor.com).) If interested, send us an e-mail with your complete address and your company logo as a jpg file in printable resolution to [info@blowerdoor.com](mailto:info@blowerdoor.com).

### **Technical Support**

Should you have unexpected technical problems while conducting BlowerDoor measurements, our tech support team is available free of charge during our office hours at the following number: +49(0)5044/975-57 (chargeable call to German landline).

## Guarantee

### **Object of the guarantee:**

#### **Minneapolis Micro Leakage Meter, Minneapolis FlowBlaster BlowerDoor standard, BlowerDoor MiniFan and BlowerDoor MultipleFan system**

Besides the guarantee set forth in the law, BlowerDoor GmbH offers you a total of four years of guarantee for the complete BlowerDoor Measurement System. The guarantee starts with date of purchase. It takes into account all claims under guarantee submitted to BlowerDoor GmbH in writing during the period of guarantee.

Should a claim under guarantee require the measuring equipment to remain at the premises of BlowerDoor GmbH for more than 7 days, customers upon request will be loaned a corresponding replacement for the duration of the repairs. BlowerDoor GmbH will bear the cost of shipping to the client's premises on the basis of standard cost of freight. Upon repair and on receipt of the repaired measuring device, customers shall send the measuring device loaned to them back to BlowerDoor GmbH at their own expense immediately. The costs as well as the risk of loss or damage on the way to or from the point where the claims under guarantee are accepted are borne by the respective shipping party.

Claims under guarantee cannot be considered

- when the measuring device or the object under guarantee has not been operated according to specifications, e.g. has not been properly handled or stored, in particular also when the operating instructions have not been observed or maintenance has been neglected,
- when the measuring device or the object under guarantee has been opened or repaired by non-authorized workshops or other people,
- when the measuring device or the object under guarantee shows damages that can be traced to wear or tear.

In accordance with this guarantee, BlowerDoor GmbH shall only provide guarantee services if the guarantee case is immediately and without any delay communicated to BlowerDoor GmbH in writing.

This guarantee shall not cover consequential damages, in particular financial losses for the customer caused by failure of the equipment.

Upon completion of the guarantee service, ownership of the parts replaced shall fall to BlowerDoor GmbH.

**Process/Delivery**

Only BlowerDoor GmbH, Zum Energie- und Umweltzentrum 1 in 31832 Springe-Eldagsen/Germany (Tel.: +49(0)5044/975-40) shall be entitled to accept claims under guarantee. Customers shall send the faulty measuring device or component to BlowerDoor GmbH. BlowerDoor GmbH shall bear the cost of return shipping on the basis of standard cost of freight.

The costs and risk of loss or damage on the way to or from the point where the claims under guarantee are received are borne by the respective shipping party.



© BlowerDoor GmbH / 2021

BlowerDoor GmbH MessSysteme für Luftdichtheit • Zum Energie- und Umweltzentrum 1 • D-31832 Springe-Eldagsen  
Phone +49 (0) 50 44 / 975 -40 • Fax +49 (0) 50 44 / 975 -44 • info@blowerdoor.com • www.blowerdoor.com